



NOCTURN HD-SDI



Features

- Color or Monochrome
- Night time broadcasting
- Remote sensing
- Vehicle dashboard camera
- Security or Surveillance
- Unmanned ground or aerial

Camera	Specifications
Resolution	1280 x 1024 Pixels
Pixel Pitch	9.7 μm x 9.7 μm
Shutter Mode	Rolling
Spectral range	Monochrome 350-1100nm Smart Color 350-650nm
Read Noise	< 4e- median at 60 Hz
Frame Rate	50 Hz or 60 Hz
Sensitivity	Full daylight to bright starlight conditions

Imaging enhancements	
Non-uniformity correction	Factory calibrated
Image processing	Noise removal, sharpening, contrast enhancement
Gain and exposure controls	Fully automatic or manual
Digital Zoom	4x

Camera format and dimensions	
Optical format	1 inch
Lens mount	C-mount
Mounting interface	1/4-20" tripod mount adapter
Dimensions	35mm x 37mm x 54mm
Weight	< 95g

Quantum Efficiency

Monochrome

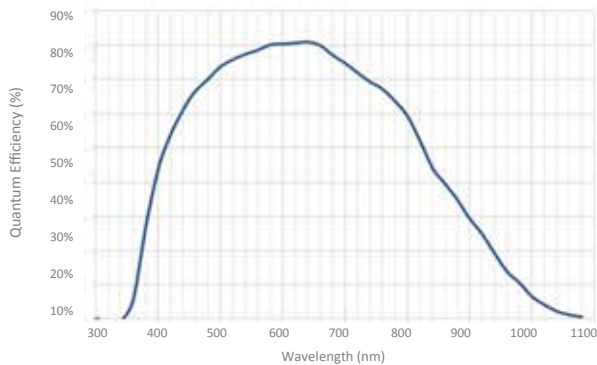

Color

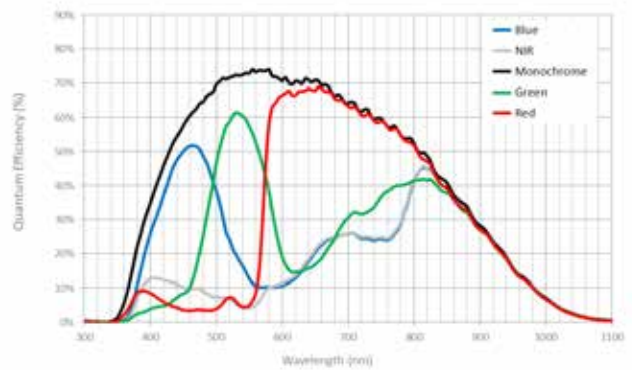



Input/Output	
Digital Video Output	HD-SDI 720p 60Hz or 50Hz
Communications	Serial over USB or TS-422

Environmental and Power	
Operating Temperature	-40°C to +60°C
Storage Temperature	-50°C to +80°C
Input Voltage	+5 to +12 VDC over GPIO Interface
Power dissipation	Monochrome < 2W (Typical) Smart Color < 2,5W (Typical)

Mechanical Dimensions for HD-SDI Camera Body (in mm)

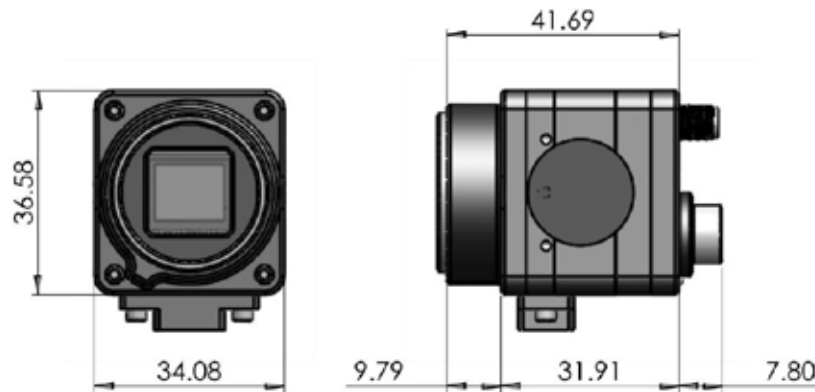

NOCTURN HD-SDI Camera is powered by the KAMELEON Color CMOS imaging sensor, or the LYNX CMOS monochrome sensor, both optimized for low light level imaging.

The KAMELEON Color and LYNX Monochrome CMOS imaging sensors are the first operational sensors specifically designed with Night Vision, Homeland Security and Surveillance applications in mind. These fully solid-state CMOS sensors provide excellent imaging across varying light conditions, from daylight to low-light levels such as those found during a quarter moon.

Both LYNX and KAMELEON CMOS imaging sensors provide full SXGA resolution at 60 frames per second, with < 4e- read out noise and without cooling.

